

DICOM Conformance Statement

IOLMaster

Version 5.5

Carl Zeiss Meditec AG

Göschwitzer Strasse 51-52

07745 Jena

Germany

www.meditec.zeiss.com

1 Conformance Statement Overview

This document is structured as suggested in the DICOM Standard (PS 3.2, 2009).

SOP Classes	User of Service (SCU)	Provider of Service (SCP)
Transfer		
Encapsulated PDF Storage	Yes	No
Multi-frame True Color Secondary Capture Image Storage	Yes	No
Workflow Management		
Modality Worklist Information Model - FIND	Yes	No

The IOLMaster does not support Media Interchange.

2 Table Of Contents

1	Conformance Statement Overview	2
2	Table Of Contents	3
3	Introduction	4
3.1	Revision History	4
3.2	Audience	4
3.3	Remarks	4
3.4	Definitions, Terms and Abbreviations	4
3.5	References	4
4	Networking	5
4.1	Implementation Model	5
4.1.1	Application Data Flow	5
4.1.2	Functional Definition Of AEs	5
4.1.2.1	Functional Definition Of Network Broker	5
4.1.3	Sequencing of Real-World Activities	5
4.2	AE Specifications	6
4.2.1	Network Broker Application Entity Specification	6
4.2.1.1	SOP Classes	6
4.2.1.1.2	Associations Policies	6
4.2.1.1.2.1	General	6
4.2.1.1.2.2	Number of Associations	6
4.2.1.1.2.3	Asynchronous Nature	7
4.2.1.1.2.4	Implementation Identifying Information	7
4.2.1.1.3	Association Initiation Policy	7
4.2.1.1.3.1	Activity – Query Modality Worklist	7
4.2.1.1.3.2	Activity – Store evidence reports	9
4.2.1.1.4	Association Acceptance Policy	10
4.3	Network Interfaces	10
4.3.1	Physical Network Interface	10
4.3.2	Additional Protocols	10
4.4	Configuration	10
4.4.1	AE Title/Presentation Address Mapping	10
4.4.1.1	Local AE Titles	10
4.4.1.2	Remote AE Titles	10
4.4.2	Parameters	10
4.4.2.1	General Parameters	10
4.4.2.2	Modality Worklist SCU Parameters	10
4.4.2.3	Storage SCU Parameters	12
5	Media Interchange	13
6	Support Of Character Sets	14
7	Security	15
8	Annexes	16
8.1	IOD Contents	16
8.1.1	Created SOP Instance(s)	16
8.1.1.1	Encapsulated PDF Information Object Definition	16
8.1.1.2	Multi-frame True Color SC Image Information Object Definition	19
8.1.2	Usage Of Attributes From Received IOD's	24
8.1.3	Attribute Mapping	24
8.1.4	Coerced/Modified Files	24
8.2	Data Dictionary Of Private Attributes	24
8.3	Coded Terminology And Templates	26
8.4	Grayscale Image Consistency	26
8.5	Standard Extended / Specialized/ Private SOP Classes	26
8.6	Private Transfer Syntaxes	26

3 Introduction

3.1 Revision History

Document Version	Author	Date	NB Version
1.0	Roberto Witt	18.12.2007	1.3.2
1.1	Patrick A. Nast	20.01.2010	1.3.6

3.2 Audience

This document is intended for hospital staff, health system integrators, software designers or implementers. The reader should have a basic understanding of DICOM.

3.3 Remarks

If another device matches this conformance statement based on the comparison with its own conformance statement, there is a chance, but no guarantee, that they interoperate. DICOM only deals with communication; it does not specify what is needed for certain applications to run on a device.

3.4 Definitions, Terms and Abbreviations

Abbreviation	Definition
AE	Application Entity
AET	Application Entity Title
DICOM	Digital Imaging and Communications in Medicine
ILE	Implicit Little Endian
IOD	Information Object Definition
JPG-1	JPEG Coding Process 1; JPEG Baseline; ISO 10918-1
MWL	Modality Work List
NB	Network Broker
RLE	Run Length Encoding
SCP	Service Class Provider
SCU	Service Class User
SOP	Service Object Pair, pair of user and provider.
TCP/IP	Transmission Control Protocol / Internet Protocol
UID	Unique Identifier
VL	Visible Light

3.5 References

Digital Imaging and Communications in Medicine (DICOM), NEMA PS 3.1-3.18, 2009.

4 Networking

4.1 Implementation Model

4.1.1 Application Data Flow

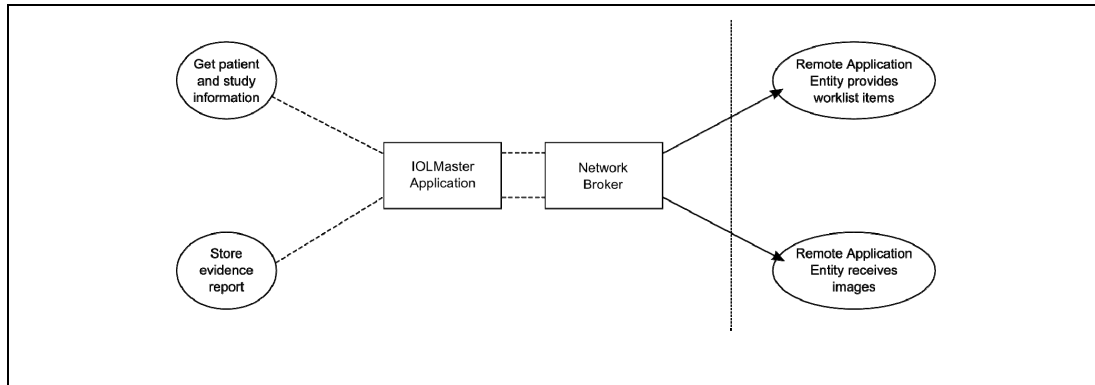

The IOLMaster Software works together with the Network Broker. Both software applications are hosted on same machine. Thus even the User Interface of the Network Broker can be used by an operator which works with the IOLMaster Application.

4.1.2 Functional Definition Of AEs

4.1.2.1 Functional Definition Of Network Broker

The IOLMaster Application allows to perform an examination of the eye of a patient, i.e. acquiring data.

4.1.3 Sequencing of Real-World Activities

To realize the real world activities, the different entities work together. The sequence diagrams shall depict the intended workflow.

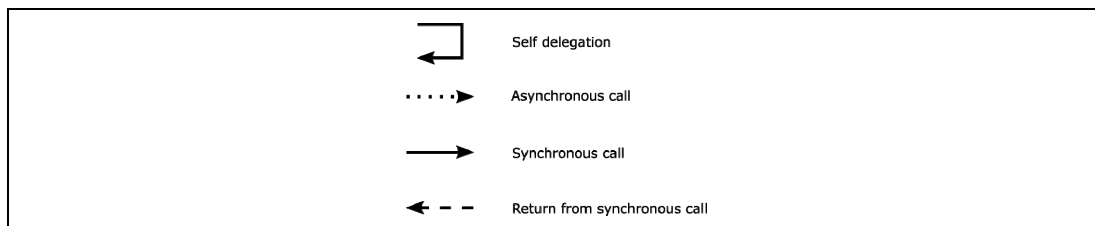

The diagrams uses slightly modified UML symbols. The asynchronous call is not depicted as suggested in UML. Some objects do have more than one dashed line. It symbolizes more than one thread.

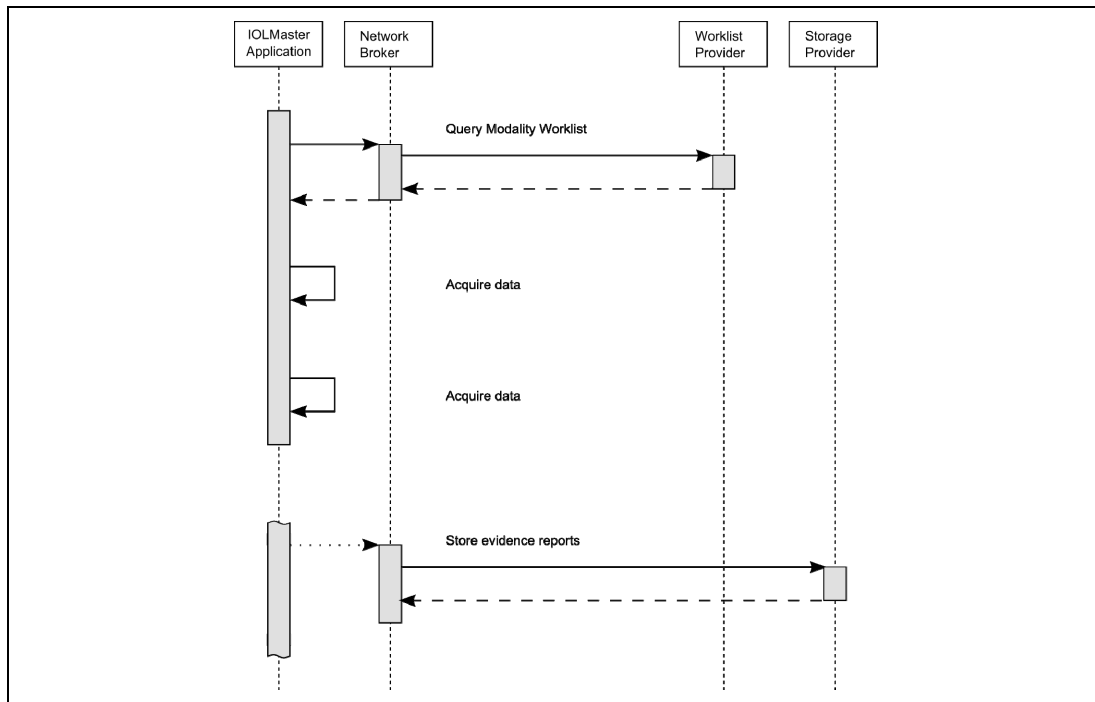

All activities are initiated by an operator.

Query Modality Worklist

When the patient arrives at the IOLMaster, then the operator queries the work list. He types in search criterias and gets matches back. Those matches are listed in a table, so the operator can select the correct entry. According to the transferred data IOLMaster creates an entry in the local database (Patient, Study, Visit for the current day). Procedure Step related information is kept temporary in the IOLMaster application. The operator can now select the patient for data acquisition.

Acquire data

The operator acquires data from patients eye.

Store evidence reports

The operator can trigger this activity by a selection of a menu entry.

4.2 AE Specifications

4.2.1 Network Broker Application Entity Specification

4.2.1.1 SOP Classes

SOP Class Name	SOP Class UID	SCU	SCP
Verification	1.2.840.10008.1.1	Yes	No
Modality Worklist Information Model - FIND	1.2.840.10008.5.1.4.31	Yes	No
Multi-frame True Color Secondary Capture Image Storage	1.2.840.10008.5.1.4.1.1.7.4	Yes	No
Encapsulated PDF Storage	1.2.840.10008.5.1.4.1.1.104.1	Yes	No

4.2.1.2 Associations Policies

4.2.1.2.1 General

DICOM standard Application Context Name is DICOM 3.0.

Application Context Name	1.2.840.10008.3.1.1.1
--------------------------	-----------------------

4.2.1.2.2 Number of Associations

The number of simultaneous associations results in two since the activities "Query Modality Worklist" and "Store Images" can run in parallel.

Maximum number of simultaneous associations	2
---	---

4.2.1.2.3 Asynchronous Nature

Network Broker does not support asynchronous communication (multiple outstanding transactions over a single Association).

4.2.1.2.4 Implementation Identifying Information

Implementation Class UID	1.2.276.0.75.2.5.10
Implementation Version Name	1.3.6.0648

4.2.1.3 Association Initiation Policy

4.2.1.3.1 Activity – Query Modality Worklist

4.2.1.3.1.1 Description and Sequencing of Activities

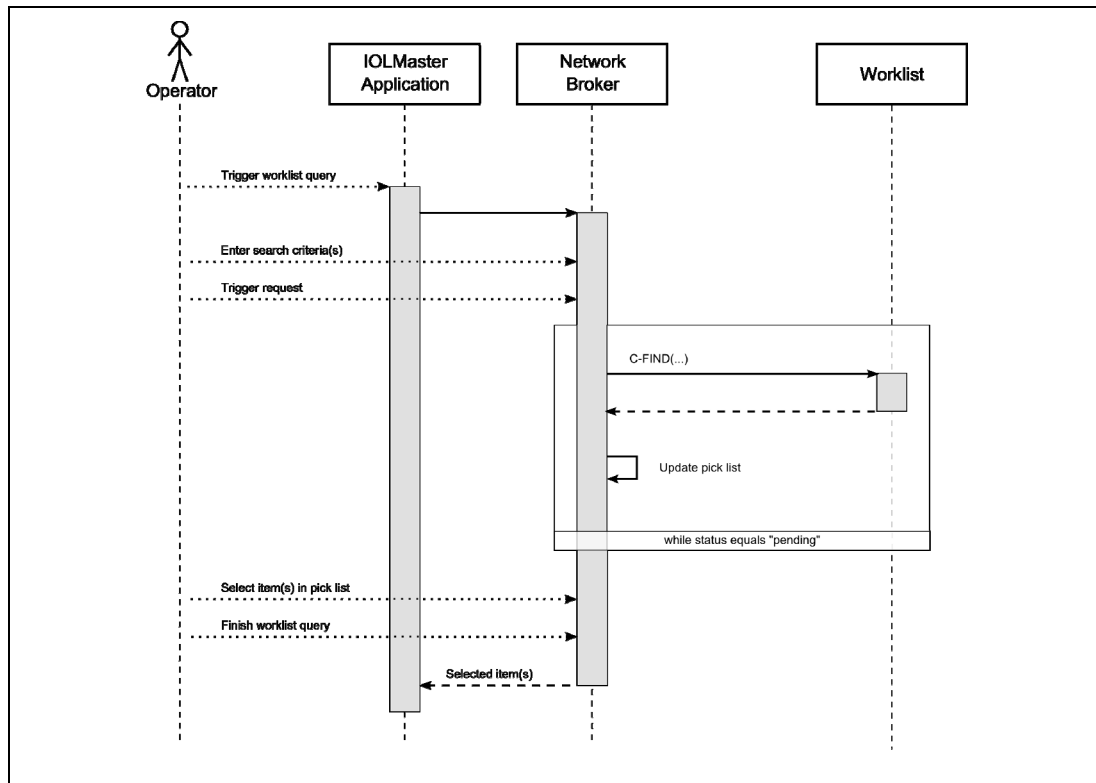

The activity "Query Modality Worklist" can be triggered at any time during the session by operator. It is meaningful to perform the query when the patient comes to the modality, then the work list contains latest information.

After activating the worklist query, the operator can fill in search criteria in the shown dialog. For instance, incomplete patient information can be used. The operator triggers the search when he or her filled in search criteria. The Network Broker sends a DICOM request, containing the search criteria. Network Broker waits for the response from the partner Application Entity. After receiving the response, Network Broker updates the pick list with the information which is included in the response. The pick list instantly shows the received information. The Network Broker will wait for additional responses as long as the Worklist Provider sends "pending" as status and the number of already received responses does not overstep 50.

After receiving all responses, the operator can select up to a certain number of items to create a new visit for. The number of selectable items can be configured. The operator finally finishes the worklist query by confirming the selection.

The IOLMaster Application takes over the selected items. It prepares data according to the selected items. For patients who relate to existing data sets of the local database, the IOLMaster Application asks the operator to update or to keep the information. For patients who do not relate to existing data sets, the IOLMaster Application creates new data sets. The IOLMaster Application handles data on Study level adequately. Data on Procedure level and Patient – Study level are kept in database. After that, the operator can start examination and to acquire data for those Studies.

4.2.1.3.1.2 Proposed Presentation Contexts

Presentation Context Table			
Abstract Syntax	Transfer Syntax	Role	Ext.

Name	UID	Name List	UID List		Neg.
Modality Worklist Information Model – FIND	1.2.840.10008.5.1.4.31	ILE	1.2.840.10008.1.2	SCU	No

4.2.1.3.1.3 SOP Specific Conformance for Modality Worklist SOP Class

Service Status	Further Meaning	Error Code	Behavior
Success	Matching is complete	0000	The Network Broker finishes receiving worklist items. The user can select items in pick list.
Pending	Matches are continuing	FF00, FF01	Network Broker puts received worklist item into the pick list. If the number of received items oversteps 50 then the SCU sends an ABORT to the SCP and the operator gets a request to specify query keys more accurate.
*	*	Any other status code	The status label of the dialog shows an error message.

Tags	Tag Name	Query key, editable by operator	Imported in App from MWL	Displayed in App	Editable	Exported in ImageIOD
Patient						
(0008,1120)	Referenced Patient Sequence		Y ¹			
(0010,0010)	Patients Name	Y	Y	Y		Y
(0010,0020)	Patient ID	Y	Y	Y		Y
(0010,0021)	Issuer Of Patient ID		Y			Y
(0010,0030)	Patients Birth Date		Y	Y		Y
(0010,0032)	Patients Birth Time					
(0010,0040)	Patients Sex		Y			Y
(0010,1000)	Other Patient IDs		Y			Y
(0010,1001)	Other Patient Names					
(0010,2000)	Medical Alerts		Y			
(0010,2110)	Contrast Allergies		Y			
(0010,2160)	Ethnic Group		Y			
(0010,21C0)	Pregnancy Status		Y			
(0010,4000)	Patient Comments		Y	Y	Y	Y
(0038,0050)	Special Needs		Y			
(0038,0500)	Patient State		Y			
Study						
(0008,0050)	Accession Number	Y	Y	Y		Y
(0008,0090)	Referring Physicians Name		Y			Y
(0020,000D)	Study Instance UID		Y			Y
(0032,1032)	Requesting Physician		Y			
(0032,4000)	Study Comments					
Requested Procedure						
(0008,1110)	Referenced Study Sequence		Y ¹			Y
(0032,1060)	Requested Procedure Description		Y			
(0032,1064)	Requested Procedure Code Sequence		Y			
(0040,1001)	Requested Procedure ID	Y	Y	Y		Y
Scheduled Procedure Step (SPS)						
(0040,0100)	Scheduled Procedure Step Sequence					
>(0008,0060)	Modality	Y	Y			
>(0040,0001)	Scheduled Station Application Entity Title	Y	Y			
>(0040,0002)	Scheduled Procedure Step Start Date	Y	Y			
>(0040,0003)	Scheduled Procedure Step Start Time		Y			
>(0040,0006)	Scheduled Performing Physicians Name		Y			
>(0040,0007)	Scheduled Procedure Step Description		Y			
>(0040,0008)	Scheduled Protocol Code Sequence		Y			
>(0040,0009)	Scheduled Procedure Step ID		Y			
(0040,2016)	Placer Order Number Imaging Service Request		Y			

¹ Imports first item in sequence only

The operator can fill in search criterions as query keys. Network Broker offers two input masks for it. Following tags are editable as search criteria in input mask "Patient Based Query".

Tag	Description
(0010,0010)	Patients Name
(0010,0020)	Patient ID
(0008,0050)	Accession Number
(0040,1001)	Requested Procedure ID

Following tags are editable as search criteria in input mask "Broad Query".

Tag	Description
(0040,0100)	Scheduled Procedure Step Sequence
>(0040,0002)	Scheduled Procedure Step Start Date
>(0008,0060)	Modality
>(0040,0001)	Scheduled Station AE Title

4.2.1.3.2 Activity – Store evidence reports

4.2.1.3.2.1 Description and Sequencing of Activities

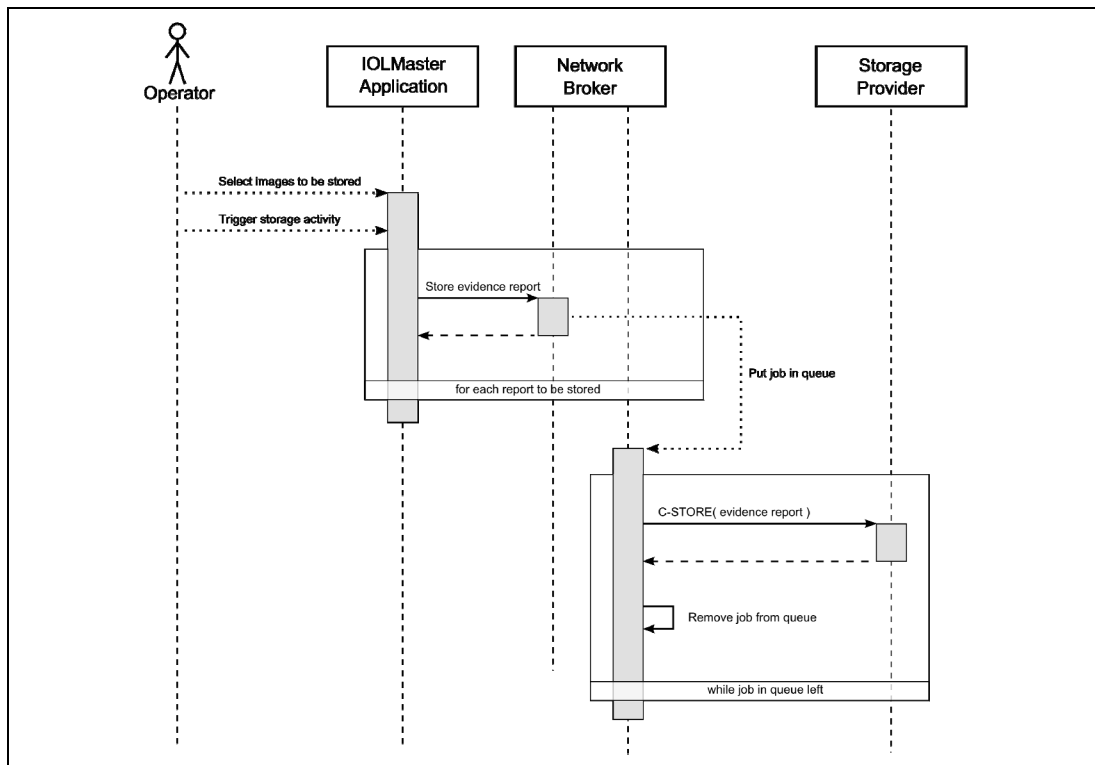

After finishing the examination, the whole Study can be submitted. The operator can initiate sending evidence reports at any time to storage entities.

The IOLMaster Application passes data to the Network Broker. The Network Broker creates immediately DICOM objects and puts a send-job for that DICOM object in a queue. The transmission of the DICOM objects is processed in the background (that means it is performed while operator can continue work with IOLMaster Application). The storage progress is reflected in a dialog. The operator can even control the storage progress. It's up to the operator if the storage progress dialog is visible or not.

The storage progress is reflected in a dialog. The operator can even control the storage progress. It's up to the operator if the storage progress dialog is visible or not.

4.2.1.3.2.2 Proposed Presentation Contexts

Presentation Context Table						
Name	Abstract Syntax		Transfer Syntax		Role	Ext. Neg.
	UID	Name List	UID List			
Multi-frame True Color SC Image Storage	1.2.840.10008.5.1.4.1.1.7.4	ILE	1.2.840.10008.1.2	SCU	No	
		JPG-1	1.2.840.10008.1.2.4.50	SCU	No	
		RLE	1.2.840.10008.1.2.5	SCU	No	
Encapsulated	1.2.840.10008.5.1.4.1.1.104.1	ILE	1.2.840.10008.1.2	SCU	No	

PDF Storage					
-------------	--	--	--	--	--

4.2.1.3.2.3 SOP Specific Conformance for Image Storage SOP Class

Service Status	Further Meaning	Error Code	Behavior
Success	Success	0000	The belonging job gets a success state and will be removed from list.
*	*	Any other status code	The job gets an error state.

4.2.1.4 Association Acceptance Policy

The Network Broker does not accept Associations.

4.3 Network Interfaces

4.3.1 Physical Network Interface

The physical network interface is not visible for the applications. The application uses the communication stack as offered by the Operating System.

4.3.2 Additional Protocols

No additional protocols are supported.

4.4 Configuration

4.4.1 AE Title/Presentation Address Mapping

The mapping from AE Title to TCP/IP addresses and ports is configurable and set at the time of installation by Installation Personnel.

4.4.1.1 Local AE Titles

The IP is not configurable by the Network Broker Configuration Tool. The IP is administrated by the Operating System. The calling AET is configurable. The calling AET is the AET of the Network Broker.

4.4.1.2 Remote AE Titles

The mapping of external AE Titles to TCP/IP addresses and ports is configurable. The Network Broker allows to set up one AE as Modality Worklist Provider and one AE as Storage Provider. For both AEs, the host or IP, the Port and the Application Entity Title must be known.

4.4.2 Parameters

4.4.2.1 General Parameters

4.4.2.2 Modality Worklist SCU Parameters

The association initiation timeout is configurable. Default is 10 seconds. Additionally, for this service file-based parameters are available. The file-based parameter describes a template for DICOM objects which is used to perform the request. Whenever the operator performs a request, the Network Broker loads the template file and creates a DICOM object of it. Then the application fills in values which was typed in by the operator in the current active input mask. A dedicated file contains template information for the Modality Worklist Query. By default, the file looks like this:

```
#Specific Character Set
(0008,0005)

#Scheduled Procedure Step Sequence
#(0040,0100)
Scheduled Station AE Title
(0040,0100) [0]>(0040,0001)
```

```
#Scheduled Step Start Date
(0040,0100) [0]>(0040,0002)
#Scheduled Step Start Time
(0040,0100) [0]>(0040,0003)
#Modality
(0040,0100) [0]>(0008,0060)
#Scheduled Performing Physicians Name
(0040,0100) [0]>(0040,0006)
#Scheduled Procedure Step Description
(0040,0100) [0]>(0040,0007)
#Scheduled Station Name
(0040,0100) [0]>(0040,0010)
#Scheduled Procedure Step Location
(0040,0100) [0]>(0040,0011)

#Scheduled Action Item Code Sequence
# (0040,0100)>(0040,0008)
#Code Value (Sequence)
(0040,0100) [0]>(0040,0008) [0]>(0008,0100)
#Coding Scheme Version
(0040,0100) [0]>(0040,0008) [0]>(0008,0103)
#Coding Scheme Designator
(0040,0100) [0]>(0040,0008) [0]>(0008,0102)
#Coding Meaning
(0040,0100) [0]>(0040,0008) [0]>(0008,0104)

#Pre-Medication
(0040,0100) [0]>(0040,0012)
#Scheduled Procedure Step ID
(0040,0100) [0]>(0040,0009)
#Requested Contrast Agent
(0040,0100) [0]>(0032,1070)
#Requested Procedure Step Status
(0040,0100) [0]>(0040,0020)

#Requested Procedure ID
(0040,1001)
#Requested Procedure Description
(0032,1060)

#Requested Procedure Code Sequence
# (0032,1064)
#Code Value
(0032,1064) [0]>(0008,0100)
#Coding Scheme Designator
(0032,1064) [0]>(0008,0102)
#Coding Scheme Version
(0032,1064) [0]>(0008,0103)
#Code Meaning
(0032,1064) [0]>(0008,0104)

#Study Instance UID
(0020,000D)
#Study Comments
(0032,4000)

#Referenced Study Sequence
# (0008,1110)
#Referenced SOP Class UID
(0008,1110) [0]>(0008,1150)
#Referenced SOP Instance UID
(0008,1110) [0]>(0008,1155)

#Requested Procedure Priority
(0040,1003)
#Patient Transport Arrangements
(0040,1004)
#Accession Number
(0008,0050)
#Requesting Physician
(0032,1032)
#Referring Physician's Name
(0008,0090)
#Placer Order Number / Imaging Service Request
(0040,2016)
#Admission ID
```

(0038,0010)
#Current Patient Location
(0038,0300)

#Referenced Patient Sequence
#(0008,1120)
#Referenced SOP Class UID
(0008,1120) [0]>(0008,1150)
#Referenced SOP Instance UID
(0008,1120) [0]>(0008,1155)

#Patient's Name
(0010,0010)
#Patient ID
(0010,0020)
#Issuer of Patient ID
(0010,0021)
#Other Patient IDs
(0010,1000)
#Other Patient Names
(0010,1001)
#Patients Birth Date
(0010,0030)
#Patients Birth Time
(0010,0032)
#Patient's Sex
(0010,0040)
#Patients's Weight
(0010,1030)
#Confidentiality constraint on patient data
(0040,3001)
#Patient State
(0038,0500)
#Ethnic Group
(0010,2160)
#Patient Comments
(0010,4000)
#Pregnancy Status
(0010,21C0)
#Medical Alerts
(0010,2000)
#Contrast Allergies
(0010,2110)
#Special Needs
(0038,0050)

4.4.2.3 Storage SCU Parameters

The association initiation timeout is configurable. Default is 10 seconds.
It is possible to activate RLE image compression.

For IOLMaster the selectable compressions for the IODs are:

- Multi-frame True Color Secondary Capture
 - No Compression
 - RLE Compression
- Encapsulated PDF
 - No selection possible

5 Media Interchange

Media Interchange is not scope of this document since Media Interchange is not supported via Network Broker.

6 Support Of Character Sets

In addition to the default character repertoire, the Defined Terms for Specific Character Set in the table are supported.

Supported Specific Character Set	
Character Set Description	Defined Term
Latin alphabet No. 1	ISO_IR 100

7 Security

The DICOM capabilities of the IOLMaster Application do not support any specific security measures.

It is assumed that IOLMaster Application is used within a secured environment. It is assumed that a secured environment includes at a minimum:

- Firewall or router protections to ensure that only approved external hosts have network access to IOLMaster Application.
- Firewall or router protections to ensure that IOLMaster Application only has network access to approved external hosts and services.
- Any communication with external hosts and services outside the locally secured environment use appropriate secure network channels (e.g. such as a Virtual Private Network (VPN))

Other network security procedures such as automated intrusion detection may be appropriate in some environments. Additional security features may be established by the local security policy and are beyond the scope of this conformance statement.

8 Annexes

8.1 IOD Contents

8.1.1 Created SOP Instance(s)

The rows of not supported modules or tags are grey.

Abbreviations used for presence of values	
VNAP	Value Not Always Present (attribute sent zero length if no value is present) – Applicable for Type 2, 2C.
ANAP	Attribute is not always present – Applicable for Type 3
ALWAYS	Attribute is always present with a value – Applicable for Type 1
EMPTY	Attribute is sent without a value – Applicable for Type 2

Abbreviations used for sources of data	
USER	Attribute value source is from user input
AUTO	Attribute value is generated automatically
MWL, MPPS, etc.	Attribute value is the same as the value received using a DICOM service such as Modality Worklist, Modality Performed Procedure Step, etc.
CONFIG	Attribute value source is a configurable parameter

8.1.1.1 Encapsulated PDF Information Object Definition

A.45.1 Encapsulated PDF Information Object Definition				
Table A.45.1-1 Encapsulated PDF IOD MODULES				
	IE	Module	Reference	Usage
	Patient	Patient	C.7.1.1	M
	Study	General Study	C.7.2.1	M
	Series	Encapsulated Document Series	C.24.1	M
	Equipment	General Equipment	C.7.5.1	M
		SC Equipment	C.8.6.1	M
	Encapsulated Document	Encapsulated Document	C.24.2	M
		SOP Common	C.12.1	M
	Image	CZM IOL Measured Values		Presence of Module: ALWAYS
		CZM IOL Formula		Presence of Module: ALWAYS
		CZM IOL Multi Formula		Presence of Module: ALWAYS
		CZM IOL Haigis-L		Presence of Module: ALWAYS
		CZM IOL Lens Database		Presence of Module: ALWAYS

Tag	VR	Name	Value	Presence of Value	Source
Information Entity 'Patient'					
Module 'Patient'					
(0010,0010)	PN	Patient's Name	Patient's full name.	VNAP	MWL, USER
(0010,0020)	LO	Patient ID	Primary hospital identification number or code for the patient.	VNAP	MWL, USER
(0010,0021)	LO	Issuer of Patient ID	Identifier of the Assigning Authority that issued the Patient ID.	VNAP	MWL
(0010,0030)	DA	Patient's Birth Date	Birth date of the patient.	VNAP	MWL, USER

	(0010,0040)	CS	Patient's Sex	Sex of the named patient. Enumerated Values: M = male F = female O = other	VNAP	MWL
	(0010,1000)	LO	Other Patient IDs	Other identification numbers or codes used to identify the patient.	VNAP	MWL
	(0010,4000)	LT	Patient Comments	User-defined additional information about the patient.	VNAP	MWL, USER
Information Entity 'Study'						
Module 'General Study'						
	(0008,0020)	DA	Study Date	Date the Study started.	VNAP	MWL, AUTO
	(0008,0030)	TM	Study Time	Time the Study started.	VNAP	MWL, AUTO
	(0008,0050)	SH	Accession Number	A RIS generated number that identifies the order for the Study.	VNAP	MWL
	(0008,0090)	PN	Referring Physician's Name	Name of the patient's referring physician	VNAP	MWL
	(0008,1110)	SQ	Referenced Study Sequence	A sequence that provides reference to a Study SOP Class/Instance pair. The sequence may have zero or more Items.	VNAP	MWL
	>(0008,1150)	UI	Referenced SOP Class UID	Uniquely identifies the referenced SOP Class. Required if Referenced Study Sequence (0008,1110) is sent.	VNAP	MWL
	>(0008,1155)	UI	Referenced SOP Instance UID	Uniquely identifies the referenced SOP Instance. Required if Referenced Study Sequence (0008,1110) is sent.	VNAP	MWL
	(0020,000D)	UI	Study Instance UID	Unique identifier for the Study.	ALWAYS	AUTO, MWL
	(0020,0010)	SH	Study ID	User or equipment generated Study identifier.	VNAP	AUTO, MWL
Information Entity 'Series'						
Module 'Encapsulated Document Series'						
	(0008,0060)	CS	Modality	"OT"	ALWAYS	AUTO
	(0020,000E)	UI	Series Instance UID	Unique identifier of the Series.	ALWAYS	AUTO
	(0020,0011)	IS	Series Number	A number that identifies the Series.	VNAP	AUTO
	(0040,0244)	DA	Performed Procedure Step Start Date	Date on which the Performed Procedure Step started.	EMPTY	
	(0040,0245)	TM	Performed Procedure Step Start Time	Time on which the Performed Procedure Step started.	EMPTY	
	(0040,0253)	SH	Performed Procedure Step ID	User or equipment generated identifier of that part of a Procedure that has been carried out within this step.	VNAP	MWL
	(0040,0254)	LO	Performed Procedure Step Description	Institution-generated description or classification of the Procedure Step that was performed.	VNAP	
	(0040,0275)	SQ	Request Attributes Sequence	Sequence that contains attributes from the Imaging Service Request. The sequence may have one or more Items.	VNAP	
	>(0040,1001)	SH	Requested Procedure	Identifier that identifies the	VNAP	MWL

			ID	Requested Procedure in the Imaging Service Request. Required if Sequence Item is present.		
Information Entity 'Equipment'						
Module 'General Equipment'						
	(0008,0070)	LO	Manufacturer	Manufacturer of the equipment that produced the composite instances.	ALWAYS	AUTO
	(0008,0080)	LO	Institution Name	Institution where the equipment that produced the composite instances is located.	VNAP	CONFIG
	(0008,0081)	ST	Institution Address	Mailing address of the institution where the equipment that produced the composite instances is located.	VNAP	CONFIG
	(0008,1010)	SH	Station Name	User defined name identifying the machine that produced the composite instances.	ALWAYS	AUTO
	(0008,1040)	LO	Institutional Department Name	Department in the institution where the equipment that produced the composite instances is located.	VNAP	CONFIG
	(0008,1090)	LO	Manufacturer's Model Name	Manufacturer's model name of the equipment that produced the composite instances.	ALWAYS	AUTO
	(0018,1000)	LO	Device Serial Number	Manufacturer's serial number of the equipment that produced the composite instances. Note: This identifier corresponds to the device that actually created the images, such as a CR plate reader or a CT console, and may not be sufficient to identify all of the equipment in the imaging chain, such as the generator or gantry or plate.	ALWAYS	AUTO
	(0018,1020)	LO	Software Versions	Manufacturer's designation of software version of the equipment that produced the composite instances.	ALWAYS	AUTO
Module 'SC Equipment'						
	(0008,0064)	CS	Conversion Type	"SYN" - Synthetic Image	ALWAYS	AUTO
Information Entity 'Encapsulated Document'						
Module 'Encapsulated Document'						
	(0008,002A)	DT	Acquisition Datetime	The date and time that the original generation of the data in the document started.	ALWAYS	AUTO
	(0020,0013)	IS	Instance Number	A number that identifies this SOP Instance. The value shall be unique within a series.	ALWAYS	AUTO
	(0028,0301)	CS	Burned In Annotation	"NO"	ALWAYS	AUTO
	(0040,A043)	SQ	Concept Name Code Sequence	Has never an item.	EMPTY	AUTO
	(0042,0010)	ST	Document Title	The value of the "Title" entry in the "Document Information Directory" as encoded in the PDF data.	VNAP	AUTO
	(0042,0011)	OB	Encapsulated	Encapsulated Document stream,	ALWAYS	AUTO

			Document	containing a document encoded according to the MIME Type.		
	(0042,0012)	LO	MIME Type of Encapsulated Document	"application/pdf"	ALWAYS	AUTO
Module 'SOP Common'						
	(0008,0005)	CS	Specific Character Set	ISO_IR 100 Character Set that expands or replaces the Basic Graphic Set.	ALWAYS	AUTO
	(0008,0016)	UI	SOP Class UID	"1.2.840.10008.5.1.4.1.1.104.1"	ALWAYS	AUTO
	(0008,0018)	UI	SOP Instance UID	Uniquely identifies the SOP Instance. See C.12.1.1.1 for further explanation. See also PS 3.4.	ALWAYS	AUTO

8.1.1.2 Multi-frame True Color SC Image Information Object Definition

A.8.5 Multi-frame True Color SC Image Information Object Definition				
Table A.8-5 MULTI-FRAME TRUE COLOR SC IMAGE IOD MODULES				
	IE	Module	Reference	Usage
	Patient	Patient	C.7.1.1	M
	Study	General Study	C.7.2.1	M
	Series	General Series	C.7.3.1	M
	Equipment	General Equipment	C.7.5.1	U
		SC Equipment	C.8.6.1	M
	Image	General Image	C.7.6.1	M
		Image Pixel	C.7.6.3	M
		Multi-frame	C.7.6.6	M
		SC Multi-frame Image	C.8.6.3	M
		SC Multi-frame Vector	C.8.6.4	C - Required if Number of Frames is greater than 1
		SOP Common	C.12.1	M

	Tag	VR	Name	Value	Presence of Value	Source
Information Entity 'Patient'						
Module 'Patient'						
	(0010,0010)	PN	Patient's Name	Patient's full name.	VNAP	MWL, USER
	(0010,0020)	LO	Patient ID	Primary hospital identification number or code for the patient.	VNAP	MWL, USER
	(0010,0021)	LO	Issuer of Patient ID	Identifier of the Assigning Authority that issued the Patient ID.	VNAP	MWL
	(0010,0030)	DA	Patient's Birth Date	Birth date of the patient.	VNAP	MWL, USER
	(0010,0040)	CS	Patient's Sex	Sex of the named patient. Enumerated Values: M = male F = female O = other	VNAP	MWL
	(0010,1000)	LO	Other Patient IDs	Other identification numbers or codes used to identify the patient.	VNAP	MWL

	(0010,4000)	LT	Patient Comments	User-defined additional information about the patient.	VNAP	MWL, USER
Information Entity 'Study'						
Module 'General Study'						
	(0008,0020)	DA	Study Date	Date the Study started.	VNAP	MWL, AUTO
	(0008,0030)	TM	Study Time	Time the Study started.	VNAP	MWL, AUTO
	(0008,0050)	SH	Accession Number	A RIS generated number that identifies the order for the Study.	VNAP	MWL
	(0008,0090)	PN	Referring Physician's Name	Name of the patient's referring physician	VNAP	MWL
	(0008,1110)	SQ	Referenced Study Sequence	A sequence that provides reference to a Study SOP Class/Instance pair. The sequence may have zero or more Items.	VNAP	MWL
	>(0008,1150)	UI	Referenced SOP Class UID	Uniquely identifies the referenced SOP Class. Required if Referenced Study Sequence (0008,1110) is sent.	VNAP	MWL
	>(0008,1155)	UI	Referenced SOP Instance UID	Uniquely identifies the referenced SOP Instance. Required if Referenced Study Sequence (0008,1110) is sent.	VNAP	MWL
	(0020,000D)	UI	Study Instance UID	Unique identifier for the Study.	ALWAYS	AUTO, MWL
	(0020,0010)	SH	Study ID	User or equipment generated Study identifier.	VNAP	AUTO, MWL
Information Entity 'Series'						
Module 'General Series'						
	(0008,0021)	DA	Series Date	Date the Series started.	ALWAYS	AUTO
	(0008,0031)	TM	Series Time	Time the Series started.	ALWAYS	AUTO
	(0008,1070)	PN	Operators' Name	Name(s) of the operator(s) supporting the Series.	ALWAYS	CONFIG
	(0018,0015)	CS	Body Part Examined	"HEAD" <i>Text description of the part of the body examined. Defined Terms: SKULL, CSPINE, TSPINE, LSPINE, SSPINE, COCCYX, CHEST, CLAVICLE, BREAST, ABDOMEN, PELVIS, HIP, SHOULDER, ELBOW, KNEE, ANKLE, HAND, FOOT, EXTREMITY, HEAD, HEART, NECK, LEG, ARM, JAW Note: Some IODs support the Anatomic Region Sequence (0008,2218), which can provide a more comprehensive mechanism for specifying the body part being examined.</i>	ALWAYS	AUTO
	(0020,000E)	UI	Series Instance UID	Unique identifier of the Series.	ALWAYS	AUTO
	(0020,0011)	IS	Series Number	A number that identifies this Series.	VNAP	AUTO

	(0020,0060)	CS	Laterality	Laterality of (paired) body part examined. Required if the body part examined is a paired structure and Image Laterality (0020,0062) or Frame Laterality (0020,9072) are not sent. Enumerated Values: R = right L = left Note: Some IODs support Image Laterality (0020,0062) at the Image level or Frame Laterality(0020,9072) at the Frame level in the Frame Anatomy functional group macro, which can provide a more comprehensive mechanism for specifying the laterality of the body part(s) being examined.	ALWAYS	AUTO
	(0040,0244)	DA	Performed Procedure Step Start Date	Date on which the Performed Procedure Step started.	EMPTY	
	(0040,0245)	TM	Performed Procedure Step Start Time	Time on which the Performed Procedure Step started.	EMPTY	
	(0040,0253)	SH	Performed Procedure Step ID	User or equipment generated identifier of that part of a Procedure that has been carried out within this step.	VNAP	MWL
	(0040,0254)	LO	Performed Procedure Step Description	Institution-generated description or classification of the Procedure Step that was performed.	VNAP	
	(0040,0275)	SQ	Request Attributes Sequence	Sequence that contains attributes from the Imaging Service Request. The sequence may have one or more Items. Included macro 'Request Attributes Macro', context 'No Baseline Context IDs defined'	VNAP	
	>(0040,0009)	SH	Scheduled Procedure Step ID	Identifier that identifies the Scheduled Procedure Step.	VNAP	MWL
	>(0040,1001)	SH	Requested Procedure ID	Identifier that identifies the Requested Procedure in the Imaging Service Request.	VNAP	MWL
Information Entity 'Equipment'						
Module 'General Equipment'						
	(0008,0070)	LO	Manufacturer	Manufacturer of the equipment that produced the composite instances.	ALWAYS	AUTO
	(0008,0080)	LO	Institution Name	Institution where the equipment that produced the composite instances is located.	VNAP	CONFIG
	(0008,0081)	ST	Institution Address	Mailing address of the institution where the equipment that produced the composite instances is located.	VNAP	CONFIG
	(0008,1010)	SH	Station Name	User defined name identifying the machine that produced the composite instances.	ALWAYS	AUTO
	(0008,1040)	LO	Institutional Department Name	Department in the institution where the equipment that produced the composite instances is located.	VNAP	CONFIG

	(0008,1090)	LO	Manufacturer's Model Name	Manufacturer's model name of the equipment that produced the composite instances.	ALWAYS	AUTO
	(0018,1000)	LO	Device Serial Number	Manufacturer's serial number of the equipment that produced the composite instances. Note: This identifier corresponds to the device that actually created the images, such as a CR plate reader or a CT console, and may not be sufficient to identify all of the equipment in the imaging chain, such as the generator or gantry or plate.	ALWAYS	AUTO
	(0018,1020)	LO	Software Versions	Manufacturer's designation of software version of the equipment that produced the composite instances.	ALWAYS	AUTO
Module 'SC Equipment '						
	(0008,0060)	CS	Modality	"OT" - IOLMaster	ALWAYS	AUTO
	(0008,0064)	CS	Conversion Type	"SYN" - Synthetic Image	ALWAYS	AUTO
Information Entity 'Image'						
Module 'General Image'						
	(0008,0008)	CS	Image Type	2 Items: 1. "DERIVED" 2. "PRIMARY"	ALWAYS	AUTO
	(0008,0022)	DA	Acquisition Date	The date the acquisition of data that resulted in this image started	ALWAYS	AUTO
	(0008,002A)	DT	Acquisition Datetime	The date and time that the acquisition of data that resulted in this image started. Note: The synchronization of this time with an external clock is specified in the Synchronization Module in Acquisition Time Synchronized (0018,1800).	ALWAYS	AUTO
	(0008,0032)	TM	Acquisition Time	The time the acquisition of data that resulted in this image started	ALWAYS	AUTO
	(0020,0013)	IS	Instance Number		ALWAYS	AUTO
Module 'Image Pixel '						
	(0028,0002)	US	Samples per Pixel	"8"	ALWAYS	AUTO
	(0028,0004)	CS	Photometric Interpretation	"RGB"	ALWAYS	AUTO
	(0028,0006)	US	Planar Configuration	"0"	ALWAYS	AUTO
	(0028,0010)	US	Rows		ALWAYS	AUTO
	(0028,0011)	US	Columns		ALWAYS	AUTO
	(0028,0034)	IS	Pixel Aspect Ratio		ALWAYS	AUTO
	(0028,0100)	US	Bits Allocated	"8"	ALWAYS	AUTO
	(0028,0101)	US	Bits Stored	"8"	ALWAYS	AUTO
	(0028,0102)	US	High Bit	"7"	ALWAYS	AUTO
	(0028,0103)	US	Pixel Representation	"0"	ALWAYS	AUTO

	(7FE0,0010)	OW /OB	Pixel Data	Contains the image pixel	ALWAYS	AUTO
Module 'Multi-frame '						
	(0028,0008)	IS	Number of Frames		ALWAYS	AUTO
Module 'SC Multi-frame Image '						
	(0028,0009)	AT	Frame Increment Pointer	"(0018,2001)" - Page Number Vector	ALWAYS	AUTO
	(0028,0301)	CS	Burned In Annotation	Indicates whether or not image contains sufficient burned in annotation to identify the patient and date the image was acquired. Enumerated Values: YES, NO	ALWAYS	AUTO
Module 'SC Multi-frame Vector '						
	(0018,2001)	IS	Page Number Vector	Multi-valued, the number of the pages in increasing order.	ALWAYS	AUTO
Module 'SOP Common'						
	(0008,0005)	CS	Specific Character Set	ISO_IR 100 Character Set that expands or replaces the Basic Graphic Set.	ALWAYS	AUTO
	(0008,0016)	UI	SOP Class UID	"1.2.840.10008.5.1.4.1.1.7.4"	ALWAYS	AUTO
	(0008,0018)	UI	SOP Instance UID		ALWAYS	AUTO
	(0020,0013)	IS	Instance Number	A number that identifies this Composite object instance.	ALWAYS	AUTO

8.1.2 Usage Of Attributes From Received IOD's

The usage of attributes of Modality Worklist IODs is described in chapter 4.2.1.3.1 Activity – Query Modality Worklist

8.1.3 Attribute Mapping

Modality Worklist	Instance IOD
Study Instance UID	Study Instance UID
Referenced Study Sequence	Referenced Study Sequence
Accession Number	Accession Number
Requested Procedure ID	Request Attributes Sequence > Requested Procedure ID
Scheduled Procedure Step Sequence > Scheduled Procedure Step ID	Request Attributes Sequence > Scheduled Procedure Step ID
Scheduled Procedure Step Sequence > Scheduled Procedure Step Description	Request Attributes Sequence > Scheduled Procedure Step Description
Scheduled Procedure Step Sequence > Schedule protocol Code Sequence	Request Attributes Sequence > Scheduled Protocol Code Sequence
Referring Physicians Name	Referring Physicians Name
Patients Name	Patients Name
Patient ID	Patient ID
Patients Birth Date	Patients Birth Date
Patients Sex	Patients Sex

8.1.4 Coerced/Modified Files

Those tags are listed in chapter 4.2.1.3.1 Activity – Query Modality Worklist. Other attributes get lost and are not available in the IOLMaster Application.

8.2 Data Dictionary Of Private Attributes

Network Broker adds IOLMaster specific attributes. The code scheme designator is 99CZM. The used groups are 7711 and 771B.

Tag	VR	VM
(771b,00xx)	LO	1
(771b,xx01)	SQ	1
(771b,xx02)	SQ	1
(771b,xx03)	SQ	1
(771b,xx04)	CS	1
(771b,xx05)	SQ	1
(771b,xx06)	LO	1
(771b,xx07)	FD	4
(771b,xx08)	CS	1
(771b,xx09)	LO	1
(771b,xx0a)	LO	1
(771b,xx0b)	FD	1
(771b,xx0c)	FD	1
(771b,xx0d)	FD	1
(771b,xx0e)	FD	1
(771b,xx0f)	FD	1
(771b,xx10)	FD	1
(771b,xx11)	FD	1
(771b,xx12)	FD	1
(771b,xx13)	FD	1
(771b,xx14)	FD	1

(771b,xx15)	FD	1
(771b,xx16)	FD	1
(771b,xx17)	FD	1
(771b,xx18)	FD	1
(771b,xx19)	FD	1
(771b,xx1a)	FD	1
(771b,xx1b)	FD	1
(771b,xx1c)	FD	1
(771b,xx1d)	FD	1
(771b,xx1e)	FD	1
(771b,xx1f)	FD	1
(771b,xx20)	FD	1
(771b,xx21)	FD	1
(771b,xx22)	FD	1
(771b,xx23)	FD	1
(771b,xx24)	FD	1
(771b,xx25)	IS	1
(771b,xx26)	FD	1
(771b,xx27)	FD	1
(771b,xx28)	FD	1
(771b,xx29)	FD	1
(771b,xx2a)	FD	1
(771b,xx2b)	FD	1
(771b,xx2c)	LO	1
(771b,xx2d)	LO	1
(771b,xx2e)	IS	1
(771b,xx2f)	FD	1
(771b,xx30)	SQ	1
(771b,xx31)	SQ	1
(771b,xx32)	SQ	1
(771b,xx33)	SQ	1
(771b,xx34)	SQ	1
(771b,xx35)	SQ	1
(771b,xx36)	SQ	1
(771b,xx37)	SQ	1
(771b,xx38)	SQ	1
(771b,xx39)	SQ	1
(771b,xx3a)	SQ	1
(771b,xx3b)	SQ	1
(771b,xx40)	FD	1
(771b,xx41)	FD	1
(771b,xx42)	FD	1
(771b,xx43)	FD	1
(771b,xx44)	FD	1
(771b,xx45)	CS	1
(771b,xx46)	CS	1
(771b,xx48)	CS	1
(771b,xx49)	FD	1
(771b,xx4A)	FD	1
(771b,xx4B)	FD	1
(771b,xx4C)	FD	1
(771b,xx4D)	FD	1

(771b,xx4E)	FD	1
(771b,xx4F)	FD	1
(771b,xx50)	FD	1
(771b,xx51)	FD	1
(771b,xx52)	FD	1
(771b,xx54)	SQ	1
(771b,xx55)	SQ	1
(771b,xx56)	SQ	1
(771b,xx57)	LO	1
(771b,xx58)	FD	1
(771b,xx59)	FD	1

8.3 Coded Terminology And Templates

The Workflow AE is capable of supporting arbitrary coding schemes for Procedure and Protocol Codes. The contents of Requested Procedure Code Sequence (0032,1064) and Scheduled Protocol Code Sequence (0040,0008) supplied in Worklist Items will be mapped to Image IOD and MPPS attributes as described in Table B.8.1-31. During installation, a service technician will establish a mapping between the site-specific codes and the Protocol Names used internally to identify acquisition protocols. The contents of Anatomic Region Sequence (0008,2218) in generated images will be filled with an anatomic code selected by the user from a catalog. The default catalog of anatomic codes corresponds to Context Group 4009 but can be extended using the Service/Installation Tool. The contents of Performed Procedure Step Discontinuation Reason Code Sequence (0040,0281) for a discontinued MPPS will be filled with a code selected by the user from a fixed list corresponding to Context Group 9300.

8.4 Grayscale Image Consistency

Not applicable.

8.5 Standard Extended / Specialized/ Private SOP Classes

Specialized or Private SOP Classes are supported.

8.6 Private Transfer Syntaxes

No Private Transfer Syntaxes are supported.